

5000 SERIES ASSEMBLY INSTRUCTIONS

1. Set the Base Assembly on the floor or table, insert the two (2) axels through the axel plates at the appropriate height for the wheel model you have purchased.
NOTE: 8" wheels use bottom bracket holes, 14" wheels use top bracket holes.
2. Put wheels on axel, slip on washers and then insert cotter pins through axel holes, then bend cotter pin legs in opposite directions.
3. Slip handle assembly down over the upright tube making sure the handle and toolbox is towards the rear of the cart, then insert the two (2) 1/4" bolts through the handle assembly, put on the two (2) 1/4" nuts and tighten firmly.
4. Hook both chains at one end, on the chain hook located on the upright tube, set tanks on cart base and place chains around tanks and hook on outside hooks so the chains are snug as possible on tanks.

1. Base Assembly (1)
2. Axels (2)
3. Wheels (2)
4. Washer (2)
5. Cotter Pin (2)
6. Handle Assembly (1)
7. 1/4" Bolts (2)
8. 1/4" Nuts (2)

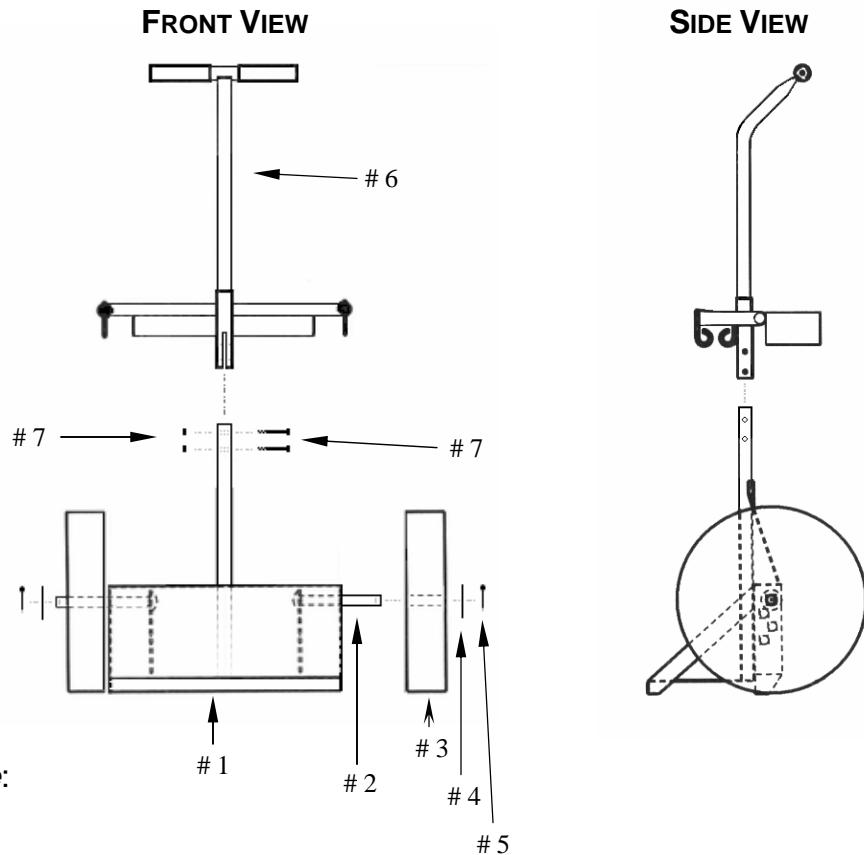

Manufactured with Pride:



Manufacturing, Inc.

Phone: (217) 339-2279

Page: www.ezeeroll.com